



Qualität von Anfang an.

Technische Daten

BAUFORM

1-teilige Körperkonstruktion, mit auswechselbarer Manschette zum Einklemmen zwischen zwei Flansche nach **EN 1092-1 Typ 11 Form B (PN10/PN16)**. Ab DN 50 Baulänge nach EN 558-1 Reihe 20.

BETÄTIGUNG

Pneumatisch doppelt- oder einfachwirkend

ANSCHLUß

Flansch DN40 ... DN300
PN 10, PN 16, AISI 150

BETRIEBSDRUCK

zwischen 2 Flanschen:

max. 16bar
Aluminium-Gehäuse max. 10bar
PTFE-Manschette max. 6bar
als Endklappe:
max. 6bar

STEUERDRUCK

6 ... 8bar
(Bei niedrigerem Steuerdruck bitte anfragen)

EINBAUWEISE

In jeder Lage.

MEDIUMTEMPERATUR

EPDM = -35°C ... +130°C*
FKM = -20°C ... +200°C
*: in Kombination mit einem Gehäuse aus
GGG-40: $t_{\min} = -20^\circ\text{C}$

UMGEBUNGSTEMPERATUR

-20°C ... +80°C
(bei höheren Temperaturen ist ein Antrieb in Hochtemperaturlösung erforderlich.)

WERKSTOFFE

Gehäuse: GGG-40
Edelstahl 1.4408
Aluminium
Scheibe: siehe Tabelle
Spindeldichtung: NBR (FKM auf Anfrage)
Welle: Edelstahl (1.4016)
Buchse: Bronze
Manschette: siehe Tabelle

STEUERMEDIUM

Gefilterte Luft (hinsichtlich Rest-Öl, Rest-Staub und Rest-Wasser).
Mindestens nach PNEUROP/ ISO-Klasse 4.

ZUSATZAUSSTATTUNG

Direkt angebautes oder separates 3/2- oder 5/2-Wegeventil, elektrische oder optische Stellungsanzeige, Stellungsregler, Mittelflanschsausführung.

Weitere technische Daten siehe Typenblatt Absperrklappe (Art. TA) und Typenblatt Antrieb (Art. ED) !

Alle Angaben sind freibleibend und unverbindlich!

Specification

DESIGN

Body consists of 1 part with exchangeable seat to be mounted between two flanges acc. to **EN 1092-1 Typ 11 Form B (PN10/PN16)**. From DN 50 face to face dimension acc. to EN 558-1 R20.

OPERATION

Pneumatic double- or single-acting

CONNECTION

Flange DN40 ... DN500
PN 10, PN 16, AISI 150

PRESSURE RANGE

between 2 flanges:
max. 16bar
Aluminium body max. 10bar
PTFE-Seat max. 6bar
dead end service:
max. 6bar

PILOT PRESSURE

6 ... 8bar
(Lower pilot pressure on request)

INSTALLATION

As desired

TEMPERATURE RANGE

EPDM = -35°C ... +130°C*
FKM = -20°C ... +200°C
*: in combination with body material
GGG-40: $t_{\min} = -20^\circ\text{C}$

AMBIENT TEMPERATURE

-20°C ... +80°C
(at higher temperatures the high- temperature version of the actuator will be necessary.)

MATERIALS

Body: GGG-40
Stainless Steel AISI 316
Aluminium
Disc: See table overleaf
Stem seal: NBR (FKM on request)
Shaft: Stainless Steel (1.4016)
Bearing shell: Bronze
Seat: See table overleaf.

PILOT MEDIA

Filtered air, subject to remaining oil, dust and water.
According at least to PNEUROP/ ISO-class 4

OPTIONS

Directly or separately mounted 3/2- or 5/2-way valve, electrical or optical position indicator, position controller, with drilled flanges (LUG-type).

Further specifications refer to data-sheet of butterfly valve (Art. TA) and actuator (Art. ED) !

The above information is intended for guidance only and the company reserves the right to change any data herein without prior notice!

Artikel:
TA-ED / TA-EE

Absperrklappe
mit pneumatischem
Schwenkantrieb
PN 10, PN 16, AISI 150

Späroguß (GGG-40)
Aluminium
Edelstahl



Type:
TA-ED / TA-EE

Butterfly valve
with pneumatic
actuator
PN 10, PN 16, AISI 150

Ductile iron (GGG-40)
Aluminium
Stainless Steel

Artikel- u. Bestellangaben: z.B. TA534007-ED620552

= Absperrklappe, GG25, Edelstahl, EPDM, DN 50 mit Antrieb ED, doppeltwirkend, Steuerkolben 55mm Ø

Absperrklappe:

1.+ 2. Stelle Produkt	3. Stelle Gehäusewerkstoff	4. Stelle Scheibenwerkstoff	5. Stelle Manschettenwerkstoff	6. Stelle Zusatzausstattung	7.+ 8. Stelle Anschlußgröße
TA = Absperrklappe zum Einklemmen zwischen zwei Flansche, voller Durchgang.	3 = Edelstahl 1.4408 5 = GGG-40 6 = Aluminium	1 = Scheibe PTFE- beschichtet 3 = Edelstahl 1.4408 5 = DN50...DN100: Stahl verzinkt, DN125...DN300: GS400 verzinkt	1 = PTFE 2 = NBR 3 = FKM 4 = EPDM 5 = Neoprene 6 = Silikon	0 = ohne 1 = PTFE- Manschette PN 10 6 = DIN - DVGW/G Zulassung	06 = DN 40 07 = DN 50 08 = DN 65 09 = DN 80 10 = DN 100 11 = DN 125 12 = DN 150 13 = DN 200 14 = DN 250 15 = DN 300

Antrieb:

9. - 11. Stelle Produkt	12. Stelle Gehäusewerkstoff	13. Stelle Dichtung	14. - 16 Stelle Kolben Ø	17. Stelle Befestigung u. Anschluß
-ED (HD) = Schwenkantrieb, doppeltwirkend -EE (HE) = Schwenkantrieb, federrückstellend	6 = Alulegierung (eloxiert)	2 = NBR 3 = FKM	055 = 55 mm 063 = 63 mm 070 = 70 mm 085 = 85 mm 100 = 100 mm 125 = 125 mm 165 = 165 mm (HD/HE) 185 = 185 mm (HD/HE) 210 = 210 mm (HD/HE)	2 = DIN-achtkant

Ordering example: e.g. TA534007-ED620552

= Butterfly valve, GG25, Stainless steel, EPDM, DN 50 with actuator ED, double acting, piston 55mm Ø

Butterfly valve:

1.+ 2. Digit Product	3. Digit Body material	4. Digit Disc material	5. Digit Seat material	6. Digit Options	7.+ 8. Digit Connection size
TA = Butterfly valve for mounting between two flanges, full bore.	3 = Stainless Steel AISI 316 5 = GGG-40 6 = Aluminium	1 = disc PTFE - coated 3 = Stainless steel 1.4408 5 = DN50...DN100: Steel zinc-plated, DN125...DN300: GS400 zinc-plated	1 = PTFE 2 = NBR 3 = FKM 4 = EPDM 5 = Neoprene 6 = Silikon	0 = no options 1 = PTFE- seat PN 10 6 = DIN - DVGW/G permission	06 = DN 40 07 = DN 50 08 = DN 65 09 = DN 80 10 = DN 100 11 = DN 125 12 = DN 150 13 = DN 200 14 = DN 250 15 = DN 300

Actuator:

9. - 11. Digit Product	12. Digit Body material	13. Digit Sealing	14. - 16 Digit Piston Ø	17. Digit Mounting and connection
-ED (HD) = Pneumatic actuator, double-acting -EE (HE) = Pneumatic actuator, spring return	6 = Aluminium alloy (anodized)	2 = NBR 3 = FKM	055 = 55 mm 063 = 63 mm 070 = 70 mm 085 = 85 mm 100 = 100 mm 125 = 125 mm 165 = 165 mm (HD/HE) 185 = 185 mm (HD/HE) 210 = 210 mm (HD/HE)	2 = DIN-octagon

Aufbau / Construction :

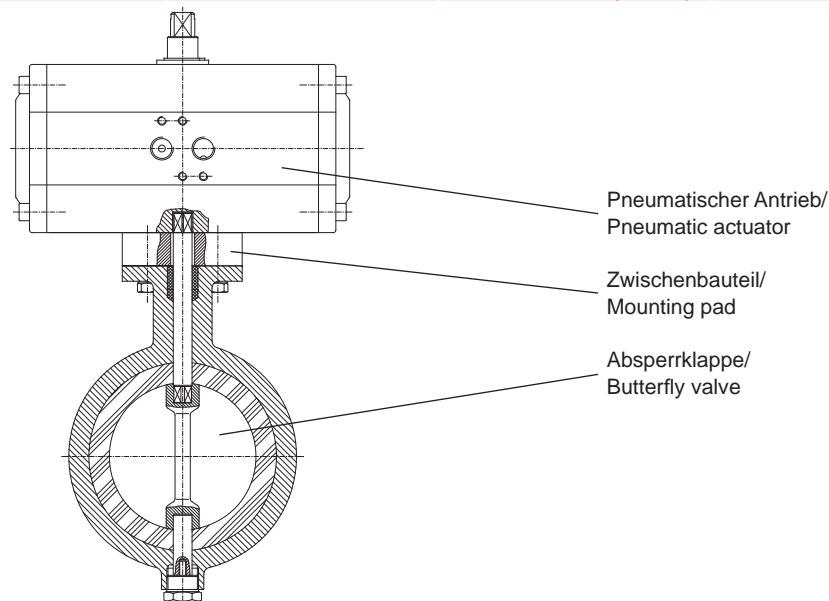

Abmessungen / Dimension

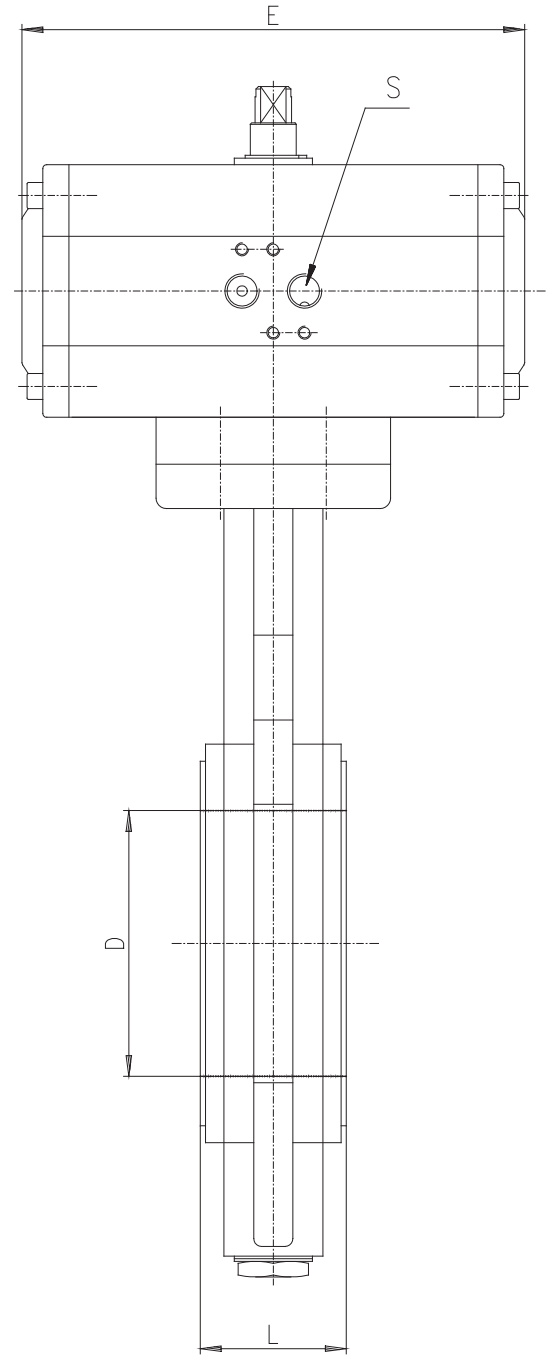
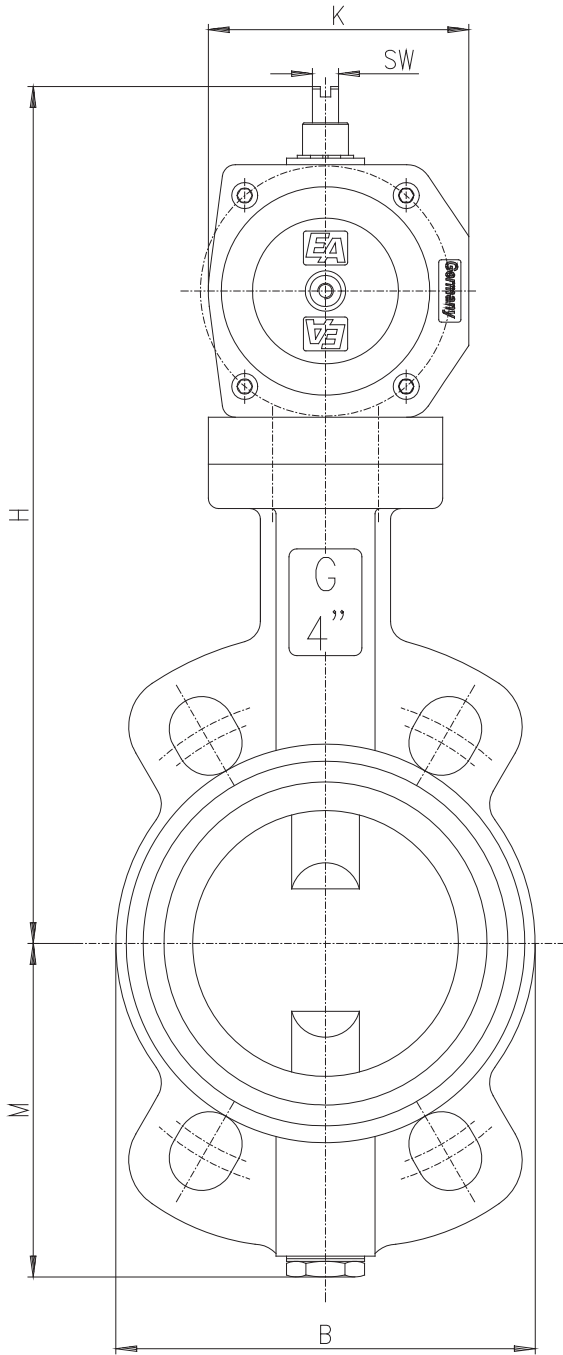

DN	ED	EE	D	B	L	H ¹⁾	H ²⁾	M	E ¹⁾	E ²⁾	K ¹⁾	K ²⁾	S ¹⁾	S ²⁾	SW ¹⁾	SW ²⁾	kg ¹⁾ *	kg ²⁾ *
40	55	63	49	84	33	249	263	75	163	197	78	86	G ¹ / ₈	G ¹ / ₈	10	10	3,6	4,4
50	55	63	55	96	43	257	271	81	163	197	78	86	G ¹ / ₈	G ¹ / ₈	10	10	4,4	5,2
65	55	70	68	116	46	267	293	89	163	193	78	100	G ¹ / ₈	G ¹ / ₄	10	10	4,9	6,6
80	63	85	81	133	46	291	318	110	197	231	86	115	G ¹ / ₈	G ¹ / ₄	10	10	6,2	8,3
100	70	100	101	152	52	318	361	128	193	266	100	143	G ¹ / ₄	G ¹ / ₄	10	10	9,1	13,0
125	85	100	126	182	56	346	374	140	231	266	115	143	G ¹ / ₄	G ¹ / ₄	10	19	11,5	14,3
150	85	125	150	207	56	362	420	155	231	340	115	174	G ¹ / ₄	G ¹ / ₄	10	20	13,8	18,4
200	125	165	200	262	60	468	476	190	340	365	174	174	G ¹ / ₄	G ¹ / ₄	28	28	23,1	24,9
250	165	165	250	317	68	506	506	220	365	365	174	174	G ¹ / ₄	G ¹ / ₄	28	28	30,9	38,1
300	165	210	298	373	78	546	603	247	365	462	174	224	G ¹ / ₄	G ¹ / ₄	28	32	38,9	61,2

Dok.-Nr.: KAT-TA-ED-3/4 - 02/2012 - Änderung: Antrieb 165 eingefügt

- 1) : gilt für Antrieb ED / for actuator ED
- 2) : gilt für Antrieb EE / for actuator EE
- * **Beachten !!** Gewicht = ohne Federn (EW)
- * **Attention !!** Weight = without spring (EW)

Beachten !!! Attention !!!

Antriebsauslegung für Standardanwendung der Absperrklappe, für saubere und selbstschmierende Medien.
Above mentioned actuators are for standard applications of the butterfly valve, for clean and self-lubricating media.



Abmessungen (Manschette aus PTFE) / Dimension (Seat: PTFE)

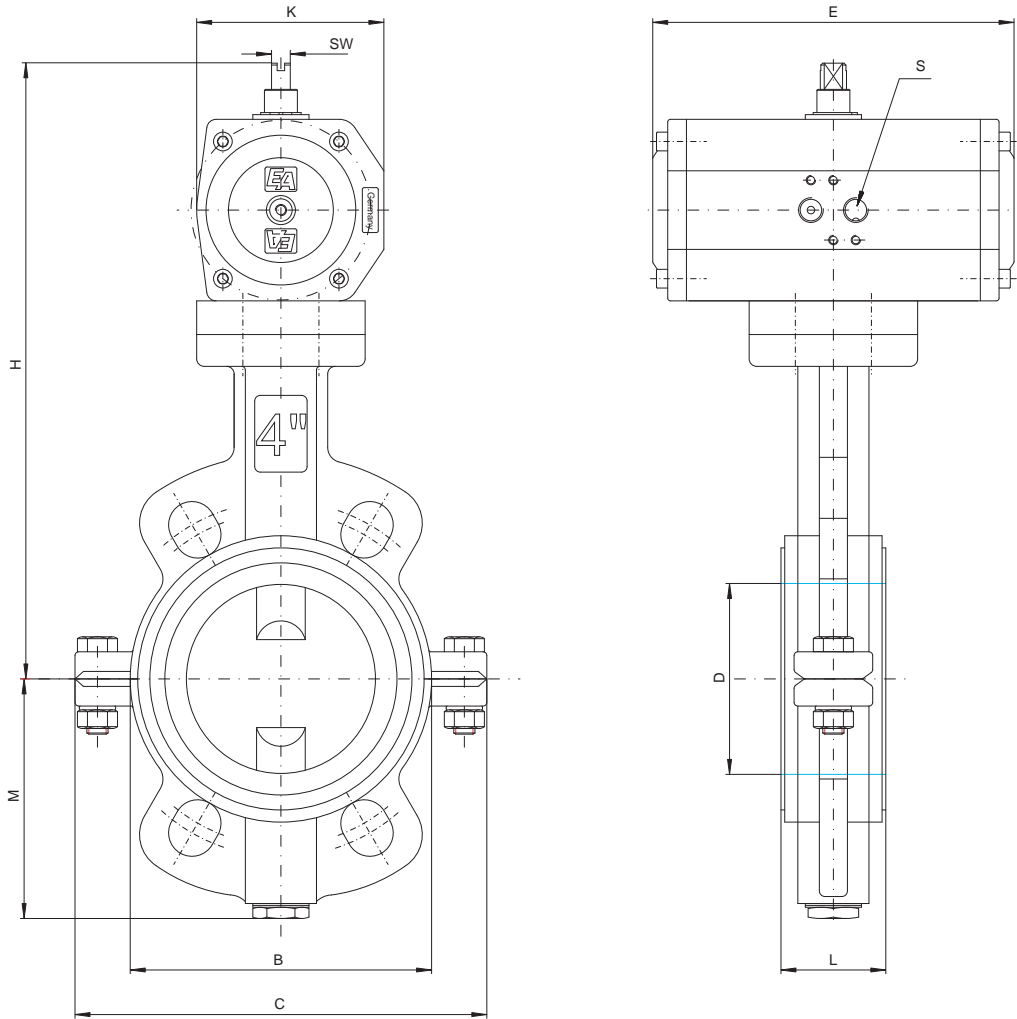

DN	ED	EE	D	B	L	C	H ¹⁾	H ²⁾	M	E ¹⁾	E ²⁾	K ¹⁾	K ²⁾	S ¹⁾	S ²⁾	SW ¹⁾	SW ²⁾	kg ¹⁾	kg ²⁾
50	55	85	55	102	43	165	257	298	81	163	231	78	115	G ¹ / ₈	G ¹ / ₄	10	10	5,4	7,9
65	55	85	68	116	46	186	267	308	89	163	231	78	115	G ¹ / ₈	G ¹ / ₄	10	10	6,0	9,0
80	70	100	81	133	46	196	303	346	110	193	266	100	143	G ¹ / ₄	G ¹ / ₄	10	19	8,6	12,5
100	70	100	101	160	52	220	318	361	128	193	266	100	143	G ¹ / ₄	G ¹ / ₄	10	19	10,4	14,3
125	85	125	126	190	56	250	346	404	140	231	340	115	174	G ¹ / ₄	G ¹ / ₄	10	20	13,2	19,4
150	85	125	150	214	56	278	362	420	155	231	340	115	174	G ¹ / ₄	G ¹ / ₄	10	20	15,3	21,7
200	125	165	200	265	60	355	440	458	190	340	365	174	174	G ¹ / ₄	G ¹ / ₄	20	20	27,8	35,2
250	125	185	250	320	68	398	470	555	220	340	420	174	224	G ¹ / ₄	G ¹ / ₄	20	20	36,1	63,2
300	165	210	298	373	78	455	518	585	247	365	462	174	224	G ¹ / ₄	G ¹ / ₄	28	32	64,5	135

¹⁾ : gilt für Antrieb ED / for actuator ED

²⁾ : gilt für Antrieb EE / for actuator EE

* **Beachten !!** Gewicht = ohne Federn (EW)

* **Attention !!** Weight = without spring (EW)

Beachten !!! Attention !!!

Antriebsauslegung für Standardanwendung der Absperrklappe, für saubere und selbstschmierende Medien.

Above mentioned actuators are for standard applications of the butterfly valve, for clean and self-lubricating media.

EU-Herstellererklärung / EU-Declaration by the manufacturer

im Sinne der EU-Maschinenrichtlinie 98/37/EG (früher 89/392/EWG, Anhang II B) Hiermit erklären wir, dass die Absperrklappen unter Anwendung nachfolgender harmonisierter Normen entwickelt und konstruiert wurden:

- EN 292 Sicherheit von Maschinen
- EN 983 Fluidtechnische Anlagen - Pneumatik
- EN 60204-1 Elektrische Ausrüstung von Maschinen

Hinweis

Die Absperrklappen sind zum Einbau in eine Maschine bestimmt. Deren Inbetriebnahme ist solange untersagt, bis festgestellt wurde, dass die Gesamtmaschine der EU-Richtlinie entspricht.

as defined by Machinery Directive 98/37/EC (former 89/392/EWG, Annex II B), we herewith declare that the butterfly valves have been developed and designed by applying the following harmonised standards:

- EN 292 Safety of machinery
- EN 983 Safety requirements for fluid power systems and components - Pneumatics
- EN 60204-1 Electrical equipment of machinery

Advice

These butterfly valves are intended to be incorporated into machinery compounds. Putting into operation of the machinery is not allowed until such time as the entire machinery is proving to comply completely with the EU Directive.