



Qualität von Anfang an.

Technische Daten

BAUFORM

2-teilige Körperkonstruktion (verschraubt), mit vollem zylindrischen Durchgang.

BETÄTIGUNG

90°-Drehung des Handhebels.

ANSCHLUß

Innengewinde: 1/4" ... 2 1/2", ISO 228
Innen-/ Außengewinde: 1/4" ... 2", ISO 228

BETRIEBSDRUCK

1/4" ... 2" : PN 30 (bis 80°C)
2 1/2" : PN 16 (bis 80°C)
Für Betriebstemperaturen über +80°C siehe Druck-Temperatur-Diagramm.

TEMPERATUR

-20°C ... +100°C.

WERKSTOFFE

Gehäuse: Messing-vernickelt
Kugel: Messing-verchromt
Dichtung: PTFE + NBR
Handhebel: Edelstahl mit Kunststoffüberzug

Alle Angaben sind freibleibend und unverbindlich!

Specification

DESIGN

Body consists of two screwed parts, full cylindrical bore.

OPERATION

Rotation of the handle through 90°.

CONNECTION

Female B.S.P. thread: 1/4" ... 2 1/2", ISO 228
Female-/ Male B.S.P thread: 1/4" ... 2", ISO 228

PRESSURE RANGE

1/4" ... 2" : PN 30 (up to 80°C)
2 1/2" : PN 16 (up to 80°C)
For higher temperatures please refer to the Pressure-Temperature-Diagram.

TEMPERATURE RANGE

-20°C ... +100°C

MATERIALS

Body: Brass (nickel-plated)
Ball: Brass (chrome-plated)
Seal: PTFE + NBR
Handle : Stainless steel plastic coated

The above information is intended for guidance only and the company reserves the right to change any data herein without prior notice!

Artikel:
CB

Kugelhahn
PN 30 / PN 16

Messing - vernickelt



Type:
CB

ball valve
PN 30 / PN 16

Brass nickel-plated

Druck - Temperatur - Diagramm /
Pressure - Temperature - Diagram

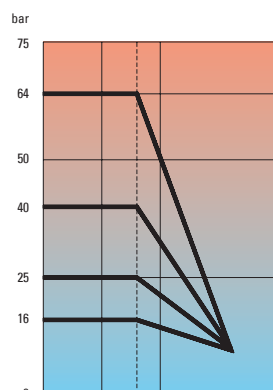

Artikel- u. Bestellangaben: z.B. CB111023

= Kugelhahn, Messing, Handhebel, Innengewinde: 1/2"

1.+ 2. Stelle Produkt	3.+ 4. Stelle Werkstoffe Gehäuse / Dichtung / Kugel	5. Stelle Betätigung	6. Stelle Zusatzausstattung	7.+ 8. Stelle Anschlußgröße (nach ISO 228)
CB = Kugelhahn	11 = Messing / PTFE / Mes- sing	1 = Handhebel	0 = Innengewinde 3 = Innen-/ Außengewinde	21 = 1/4" 22 = 3/8" 23 = 1/2" 24 = 3/4" 25 = 1" 26 = 1 1/4" 27 = 1 1/2" 28 = 2" 29 = 2 1/2"

Ordering example: e.g. CB111023

= ball-valve, brass, handle, female thread: 1/2"

1.+ 2. Digit Product	3.+ 4. Digit Material Body / seal / ball	5. Digit Operation	6. Digit Options	7.+ 8. Digit Connection size (acc. to ISO 228)
CB = Ball-valve	11 = Brass / PTFE / Brass	1 = Handle	0 = Female thread 3 = Female-/ Male thread	21 = 1/4" 22 = 3/8" 23 = 1/2" 24 = 3/4" 25 = 1" 26 = 1 1/4" 27 = 1 1/2" 28 = 2" 29 = 2 1/2"

Abmessungen / Dimensions

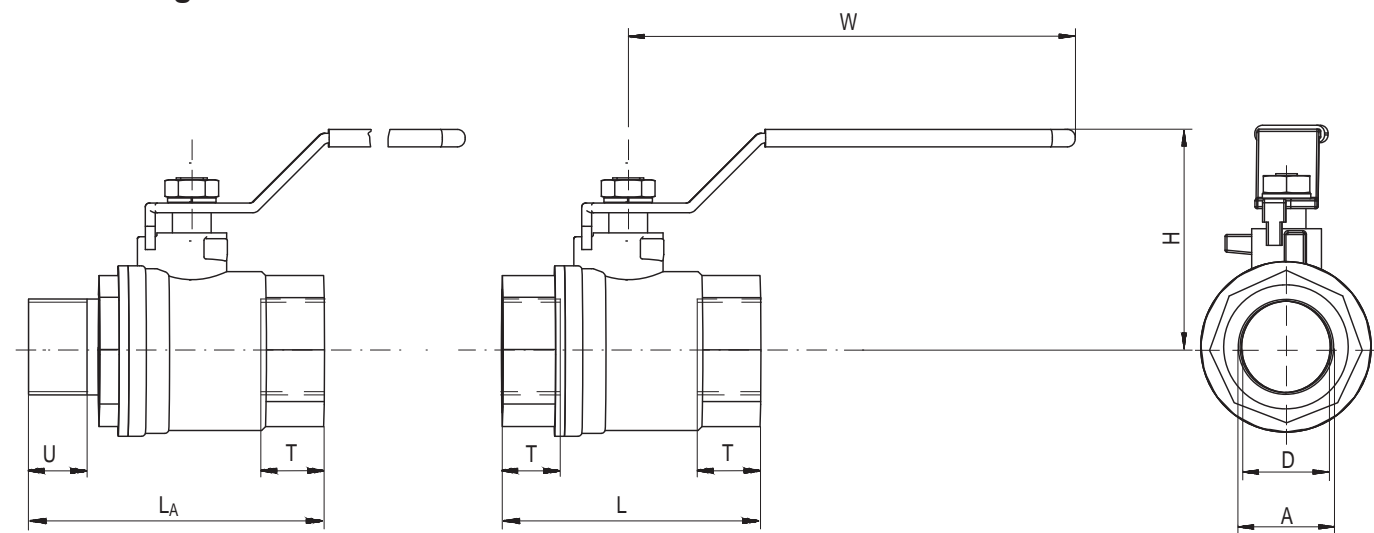

A ["]	DN [mm]	D [mm]	L [mm]	LA [mm]	H [mm]	W [mm]	T [mm]	U [mm]	M [kg]	PN [bar]
1/4	10	10	41,5	46,0	45	85	9	8	0,100	30
3/8	10	10	41,5	52,5	45	85	9	11,5	0,100	30
1/2	15	15	51,0	57,5	50	110	11,5	10	0,150	30
3/4	20	19	59,5	65,0	55	120	12,5	11,5	0,200	30
1	25	24,5	69,0	76,0	65	120	14,5	11,5	0,350	30
1 1/4	32	30	77,0	90,0	65	130	16,5	14	0,600	30
1 1/2	40	39,5	89,5	99,5	80	140	16,5	14	0,900	30
2	50	49,5	108,5	116,0	95	165	16,5	18	1,250	30
2 1/2	65	64,5	126,0	-	115	275	16,5	-	2,700	16



Stückliste / Part List

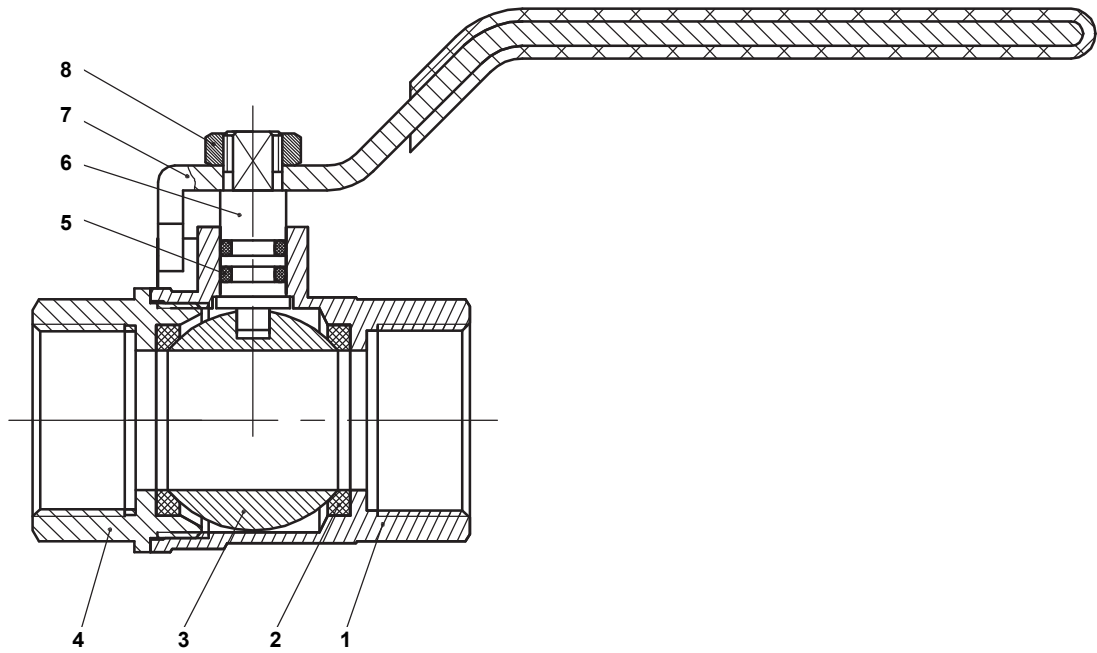

No.	Bezeichnung	Description	Material	Material
1	Gehäuse	Body	Messing vernickelt	Brass nickel-plated
2	Kugeldichtung	Ball seals	PTFE	PTFE
3	Kugel	Ball	Messing verchromt	Brass chrome-plated
4	Anschlussende	Connection end	Messing vernickelt	Brass nickel-plated
5	O-Ring	O-ring	NBR	NBR
6	spindel	Stem	Messing vernickelt	Brass nickel-plated
7	Handhebel	Handle	Edelstahl	Stainless steel
8	Sechskantschraube	Hexagon screw	Messing vernickelt	Brass nickel-plated

Dok.-Nr.: KAT-CB-3/3 - 09.01.12 - Änderung: Maß, H + W geändert

Hinweis

Bei den in dieser Dokumentation beschriebenen Produkten, in der von uns gelieferten Form, handelt es sich weder um Maschinen gemäß Artikel 2 Absatz a noch um unvollständige Maschinen gemäß Artikel 2 Absatz g im Sinne der Richtlinie 2006/42/EG über Maschinen.

Advice

The products described in this documentation in the conditions of our delivery are no machinery according to annex 2 paragraph a respectively no partly completed machinery according to annex 2 paragraph g of the directive 2006/42/EC on machinery.

