



Qualität von Anfang an.

Technische Daten

BAUFORM

3-Wege Kugelhahn, allseitig dichtend, nicht überschneidungsfrei, mit ausblässicherer Spindel mit Anti Statik Ausführung, mit Flanschplatte nach ISO 5211 für Antriebsaufbau.

KUGELBOHRUNG

L- oder T-Kugelbohrung

BETÄTIGUNG

90°-Drehung des Handhebels. (Um jeweils 180° gegen die Spindel versetzbar.)

ANSCHLUß

Flansch DN15 ... DN200,
Flansch PN 16 bemessen und gebohrt.
Flansche PN16 - DN65 werden in 4-Loch-Ausführung geliefert!
Anschweißenden DN15 ... DN100.
Einschweißenden DN15 ... DN100.
Gewindeanschluss: ½" ... 4" nach DIN 2999

BETRIEBSDRUCK

Flanschanschluß: PN 16
Gewindeanschluß: PN40
Anschweißenden:

TEMPERATUR

-20°C bis max. +150°C

Bei Mediumtemperaturen über 80°C, bzw. stark schwankenden Mediumtemperaturen, empfehlen wir eine Druckausgleichsbohrung in der Kugel. Bei zur Dampfbildung neigenden Medien ist eine Ausgleichsbohrung zwingend erforderlich.

Bitte bei Ihrer Bestellung angeben.

WERKSTOFFE

Gehäuse: Edelstahl 1.4408
Kugel: Edelstahl 1.4401
Kugeldichtung: PTFE
Spindeldichtung: PTFE / FKM
Handhebel: Edelstahl (DN15 - DN50)
Stahl (DN65 - DN 200)

ZUSATZAUSSTATTUNG

Pneumatischer oder elektrischer Schwenkantrieb. 4-Wege Ausführung

Alle Angaben sind freibleibend und unverbindlich!

Specification

DESIGN

3-Way Ball-valve, sealed on all ports, not overlapp-free, blow out proof stem design with anti-static device, with mounting pad for actuator acc. to ISO 5211.

CONFIGURATION

L- or T-configuration

OPERATION

Rotation of the handle through 90°. (Handle is reversible through 180°.)

CONNECTION

Flange connection DN15 ... DN200.
Flange dimensioned and drilled acc. PN 16.
Flanges PN16 - DN65 will be delivered in 4-hole execution!
Butt weld connection DN15 ... DN100.
Socket weld connection DN15 ... DN100.
Threaded connection: ½" ... 4" acc. to DIN 2999.

PRESSURE RANGE

Flanged connection: PN 16
Threaded connection: PN40
Welded connection:

TEMPERATURE RANGE

-20°C up to +150°C.

At media temperature above 80°C or large oscillating media temperatures we recommend a pressure compensation bore in the ball. At media which tend to steam-building the pressure compensation bore is compellingly required.

Please mention in your order.

MATERIALS

Body: Stainless Steel 1.4408
Ball: Stainless Steel 1.4401
Ball seal: PTFE
Spindle seal: PTFE / FKM
Handle : Stainless steel(DN15 - DN50)
Carbon steel(DN65 - DN200)

OPTIONS

Pneumatic or electric actuator,
4-way version

The above information is intended for guidance only and the company reserves the right to change any data herein without prior notice!

Artikel:
ZD

3-Wege Kugelhahn

PN 16 / PN 40

Edelstahl



Type:
ZD

3-way ball valve

PN 16 / PN 40

stainless steel



Artikel- u. Bestellungenaben: z.B. ZD311407

= 3-Wege Flansch-Kugelhahn, Edelstahl / PTFE / Edelstahl, Handhebel, L-Bohrung, DN 50

1.+ 2. Stelle Produkt	3.+ 4. Stelle Werkstoffe Gehäuse / Dichtung / Kugel	5. Stelle Betätigung	6. Stelle Kugelbohrung	7.+ 8. Stelle Anschlußgröße		
ZD = 3-Wege Kugelhahn	31 = Edelstahl / PTFE / Edelstahl	1 = Handhebel	4 = L-Bohrung 5 = T-Bohrung	Flansch- anschluß	Gewinde- anschluß	Anschweiß- enden
				02 = DN 15 03 = DN 20 04 = DN 25 05 = DN 32 06 = DN 40 07 = DN 50 08 = DN 65 09 = DN 80 10 = DN 100 11 = DN 125 12 = DN 150 13 = DN 200	23 = 1/2" 24 = 3/4" 25 = 1" 26 = 1 1/4" 27 = 1 1/2" 28 = 2" 29 = 2 1/2" 30 = 3" 31 = 4"	62 = DN 15 63 = DN 20 64 = DN 25 65 = DN 32 66 = DN 40 67 = DN 50 68 = DN 65 69 = DN 80 70 = DN 100

Ordering example: e.g. ZD311407

= 3-way Flange ball-valve, Stainless Steel / PTFE / Stainless Steel, handle, L-configuration, DN 50

1.+ 2. Digit Product	3.+ 4. Digit Material Body / seal / ball	5. Digit Operation	6. Digit Configuration	7.+ 8. Digit Connection size		
ZD = 3-way ball-valve,	31 = Stainless Steel / PTFE / Stainless Steel	1 = Handle	4 = L-configuration 5 = T-Configuration	Flanged connection	Threaded connection	Welded connection
				02 = DN 15 03 = DN 20 04 = DN 25 05 = DN 32 06 = DN 40 07 = DN 50 08 = DN 65 09 = DN 80 10 = DN 100 11 = DN 125 12 = DN 150 13 = DN 200	23 = 1/2" 24 = 3/4" 25 = 1" 26 = 1 1/4" 27 = 1 1/2" 28 = 2" 29 = 2 1/2" 30 = 3" 31 = 4"	62 = DN 15 63 = DN 20 64 = DN 25 65 = DN 32 66 = DN 40 67 = DN 50 68 = DN 65 69 = DN 80 70 = DN 100

Schaltmöglichkeiten / Operation methods :

Handhebel- bzw. Antriebs- montage / Handle or actuator mounting	T-Bohrung / T-configuration				L-Bohrung / L-configuration		
	1	2	3	4	5	6	7
Stellung 0° position 0°							
Stellung 90° position 90°							

Hinweis

Bei den in dieser Dokumentation beschriebenen Produkten, in der von uns gelieferten Form, handelt es sich weder um Maschinen gemäß Artikel 2 Absatz a noch um unvollständige Maschinen gemäß Artikel 2 Absatz g im Sinne der Richtlinie 2006/42/EG über Maschinen.

Advice

The products described in this documentation in the conditions of our delivery are no machinery according to annex 2 paragraph a respectively no partly completed machinery according to annex 2 paragraph g of the directive 2006/42/EC on machinery.



**Stückliste DN15 ... DN50 /
Parts list DN15 ... DN50:**

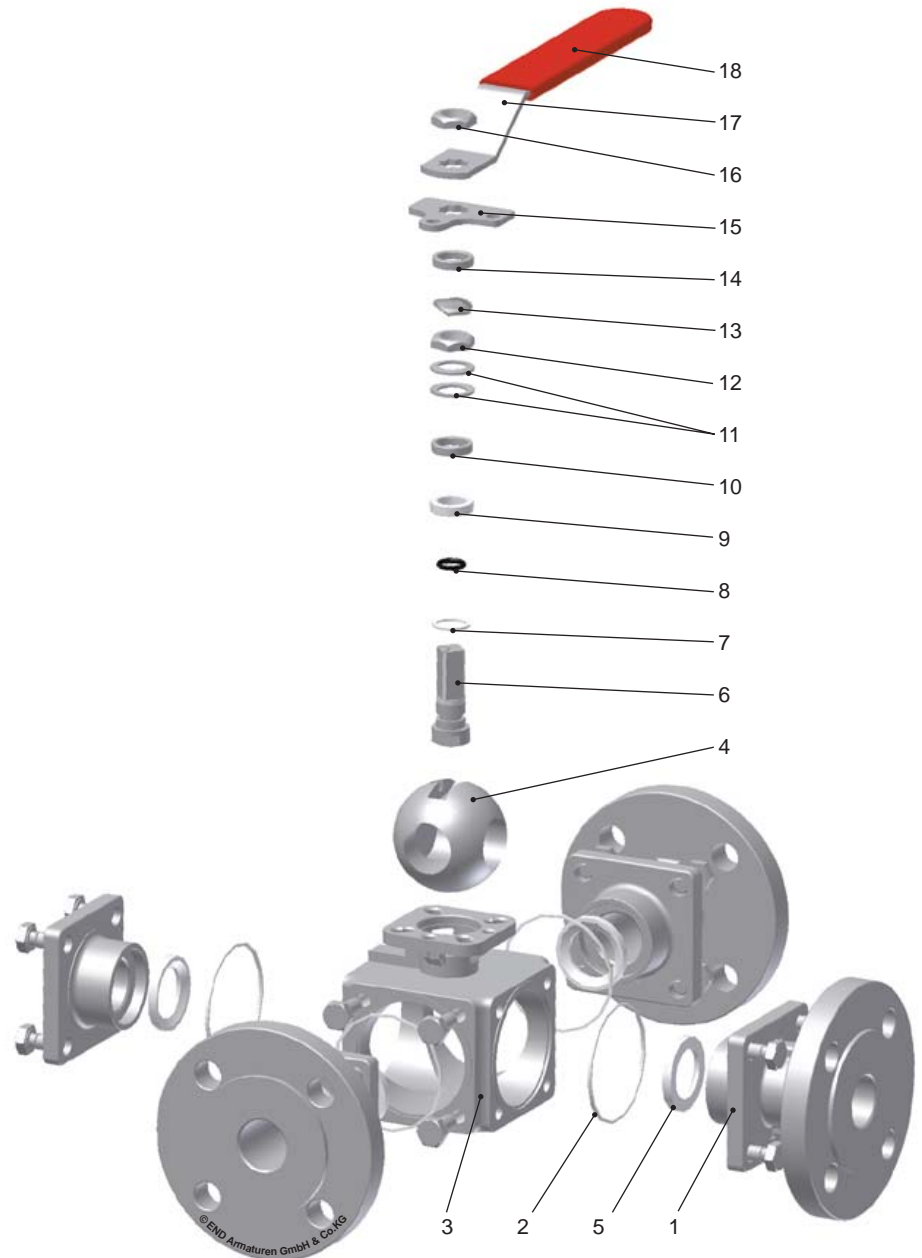

**Flanschanschluß /
flanged connection**

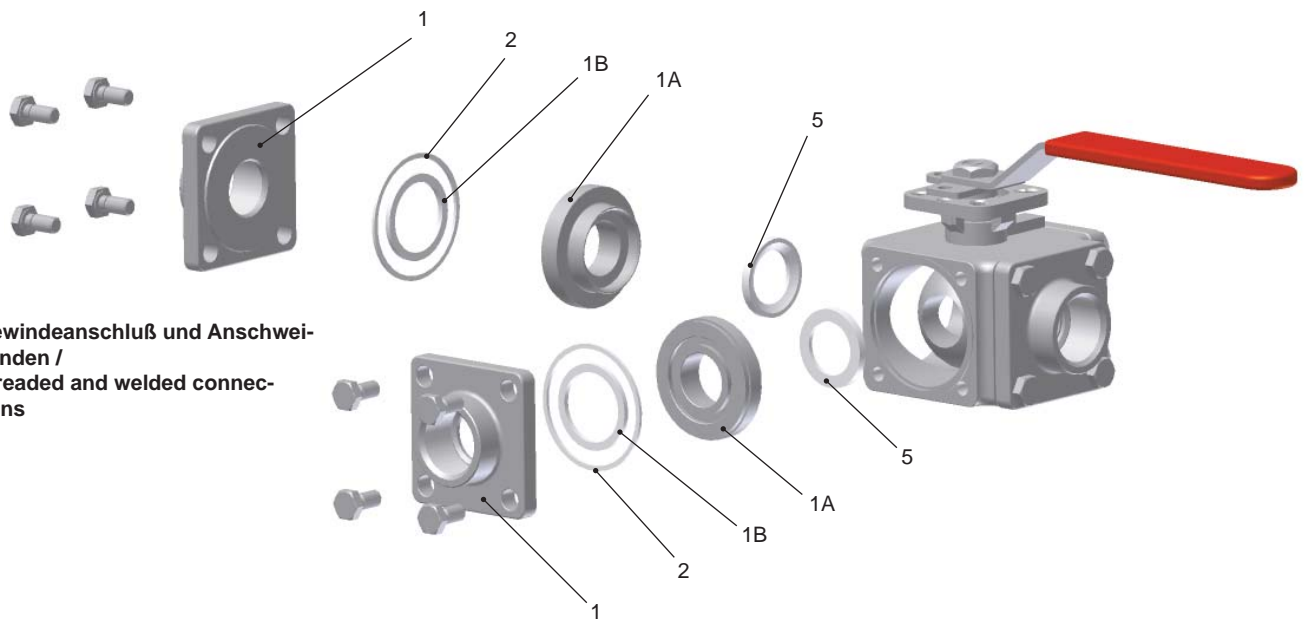

**Gewindeanschluß und Anschwei-
ßenden /
threaded and welded connec-
tions**



**Stückliste DN65 ... DN100 /
Parts list DN65 ... DN100:**

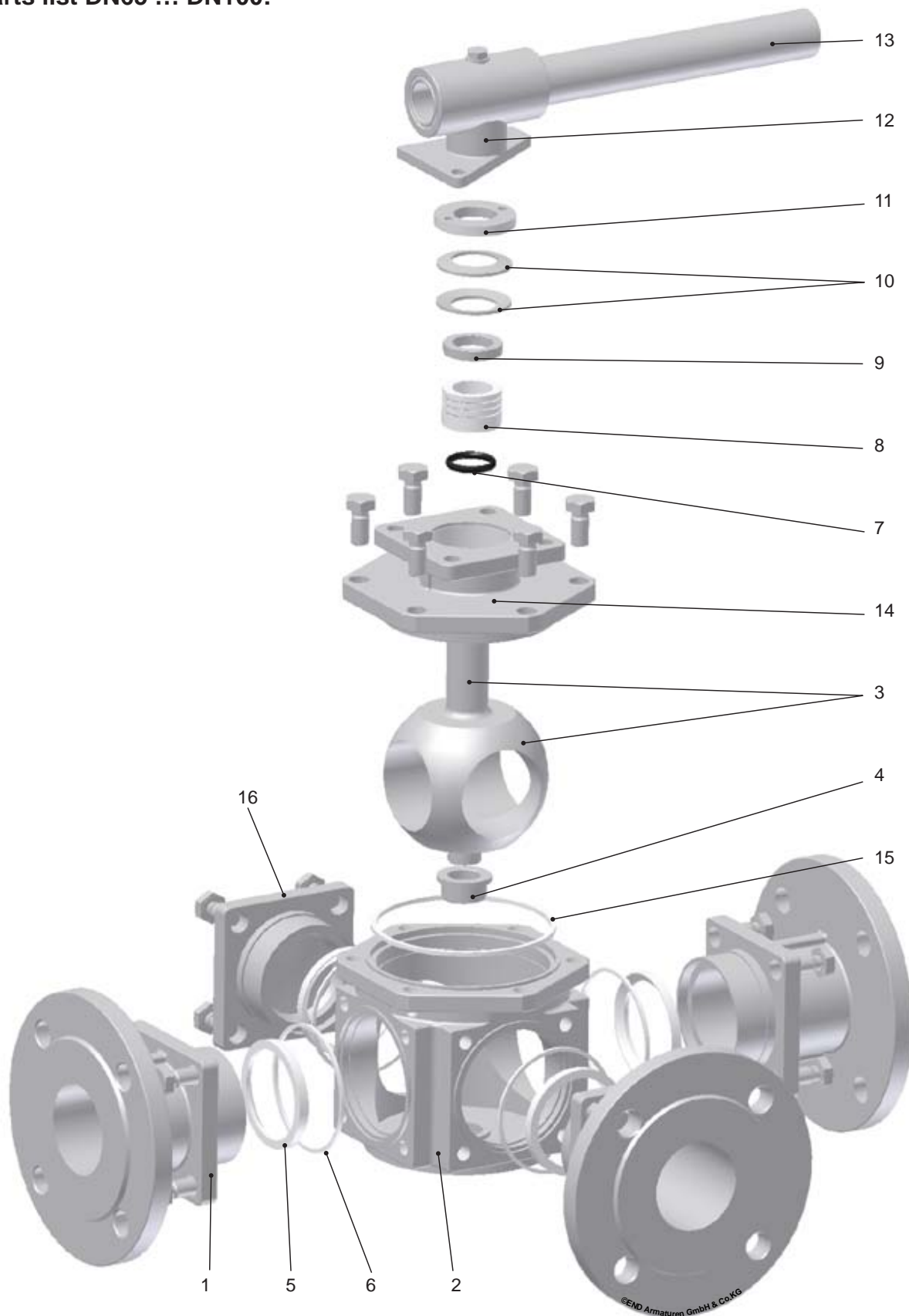

DN15 ... DN50

Pos.	Benennung	Description	Material	Material
1	Anschlußflansch	Flange end	Edelstahl 1.4408	Stainless steel CF8M
1A	Dichtung Aufnahme	Housing gasket	Edelstahl 1.4408	stainless steel CF8M
1B	Aufnahme Kugeldichtung	Seat housing	PTFE	PTFE
2	Dichtung	Gasket	PTFE	PTFE
3	Gehäuse	Body	Edelstahl 1.4408	Stainless steel CF8M
4	Kugel	Ball	Edelstahl 1.4401	Stainless steel 314
5	Kugeldichtung	Seats	PTFE	PTFE
6	Spindel	Stem	Edelstahl 1.4401	Stainless steel 316
7	Druckscheibe	Thrust washer	<ul style="list-style-type: none"> • PTFE + 15% Glasfiber (<i>Kugelhahn ohne Anti Statik Spindel</i>) • Graphit (<i>Kugelhahn mit Anti Statik Spindel</i>) 	<ul style="list-style-type: none"> • PTFE + 15% Glass Fiber (<i>ball valve without Anti-static-device</i>) • Graphite (<i>ball valve with anti-static device</i>)
8	O- Ring	O-Ring	FKM	FKM
9	Spindeldichtung	Stem Packing	PTFE	PTFE
10	Scheibe	Gland	Edelstahl 1.4301	Stainless steel 304
11	Tellerfeder	Disk washer	Edelstahl 1.4310	Stainless steel 301
12	Spindelmutter	Stem nut	Edelstahl 1.4301	Stainless steel 304
13	Verdrehsicherung	Nut stop	Edelstahl 1.4301	Stainless steel 304
14	Distanzscheibe	Space washer	Edelstahl 1.4301	Stainless steel 304
15	Anschlagplatte	Plater	Edelstahl 1.4301	Stainless steel 304
16	Handhebelmutter	Handle nut	Edelstahl 1.4301	Stainless steel 304
17	Handhebel	Handle	Edelstahl 1.4301	Stainless steel 304
18	Überzug	Cover	Kunststoff	Plastic

DN65 ... DN100

Pos.	Benennung	Description	Material	Material
1	Anschlußflansch	Flange end	Edelstahl 1.4408	Stainless steel CF8M
2	Gehäuse	Body	Edelstahl 1.4408	Stainless steel CF8M
3	Spindel mit Kugel	Stem with Ball	Edelstahl 1.4401 Edelstahl 1.4401	Stainless steel 314 Stainless steel 314
4	Kugelaufleger	Housing	PTFE + 50% Edelstahl	PTFE + 50% Stainless steel
5	Kugeldichtung	Seats	PTFE	PTFE
6	Dichtung	Gasket	PTFE	PTFE
7	O- Ring	O-Ring	FKM	FKM
8	Spindeldichtung	Stem Packing	PTFE	PTFE
9	Scheibe	Gland washer	Edelstahl 1.4301	Stainless steel 304
10	Tellerfeder	Disk washer	Edelstahl 1.4310	Stainless steel 301
11	Scheibe	Gland	Edelstahl 1.4301	Stainless steel 304
12	Handhebelaufnahme	Handle head	Edelstahl 1.4308	Stainless steel CF8
13	Handhebel	Lever	Stahl	Carbon steel
14	Deckel	Bonnet	Edelstahl 1.4408	Stainless steel CF8M
15	Deckeldichtung	Bonnet Gasket	PTFE	PTFE
16	Verschlussdeckel	Bank End	Edelstahl 1.4408	Stainless steel CF8M



Abmessungen DN15 ... DN50 / Dimension DN15 ... DN50:

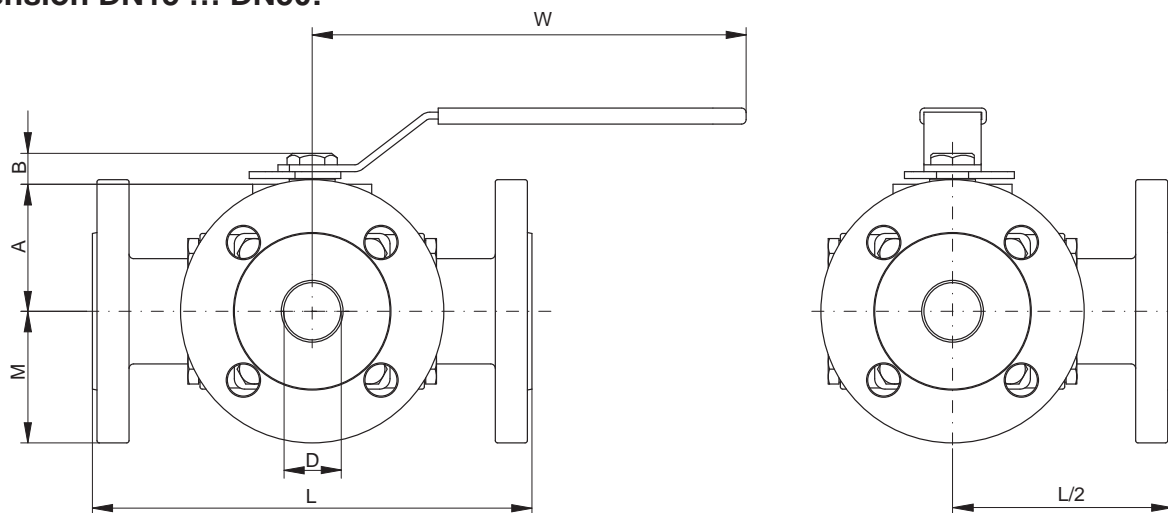

Gewindeanschluss /
Threaded connection

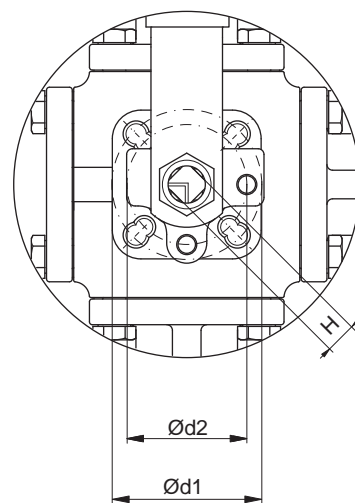
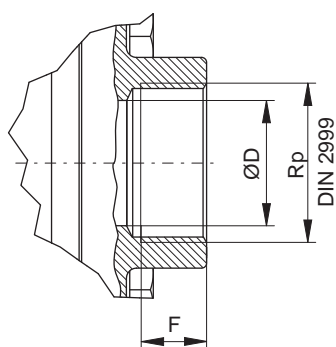

Einschweißende /
Socket weld connection

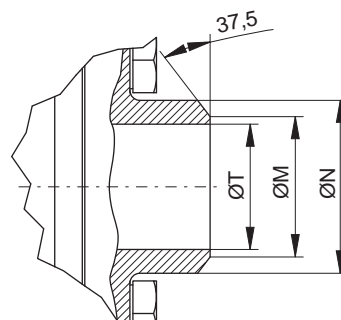
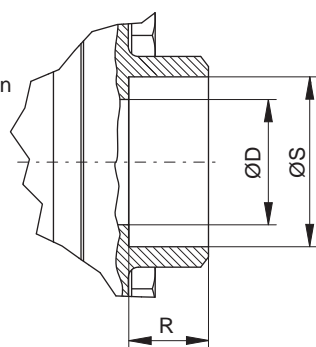

Anschweißende /
Butt weld connection

DN	Rp	L ⁽¹⁾	L ⁽²⁾	L ⁽³⁾	M	A	B	W	Ød1	Ød2	H	ØD	ØS	F	R	ØT	ØM	ØN
	["]	[mm]	[mm]	[mm]	[mm]	[mm]	[mm]	[mm]	[mm]	[mm]	[mm]	[mm]	[mm]	[mm]	[mm]	[mm]	[mm]	[mm]
15	½	160	160	105	47,5	41	11	130	42	36	9	15	21,7	20,0	12,7	15	17,5	22,5
20	¾	177	177	112	52,5	49	14	165	50	42	11	20	27,1	19,0	14,3	20	22,5	27,5
25	1	190	200	128	57,5	55	14	163	50	42	11	25	33,9	19,6	15,9	25	28	34,5
32	1¼	208	218	140	70	63	18	205	70	50	14	32	42,5	24,5	17,5	32	35	42,8
40	1½	234	234	160	75	74	18	205	70	50	14	38	48,6	26,0	19,1	38	41	49
50	2	273	273	192	82,5	93	23	325	102	70	17	50	61,1	25,0	22,2	50	54	61

⁽¹⁾ : gilt für Kugelhahn PN16 / for ball valve PN16

⁽²⁾ : gilt für Kugelhahn PN40 / for ball valve PN40

⁽³⁾ : gilt für Kugelhahn mit Anschweißenden u. Gewindeanschluss / for ball valve with welded and threaded connection



**Abmessungen DN65 ... DN100 /
Dimension DN65 ... DN100:**

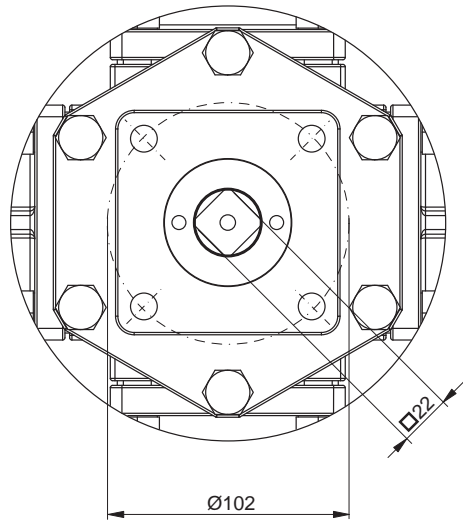
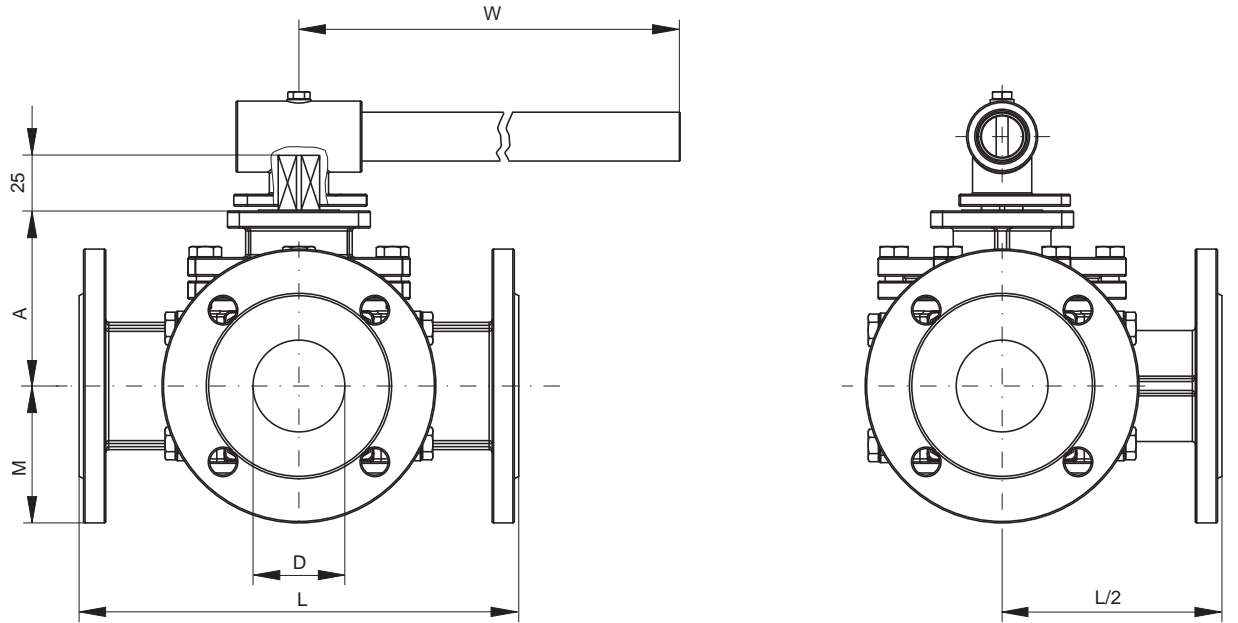

Gewindeanschluss /
Threaded connection

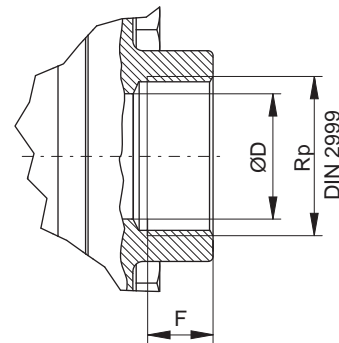

Einschweißende /
Socket weld connection

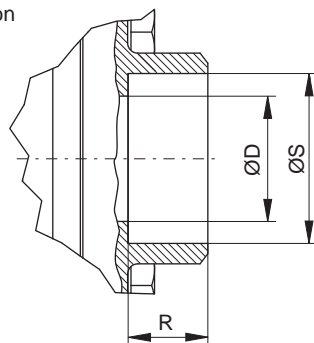

Anschweißende /
Butt weld connection

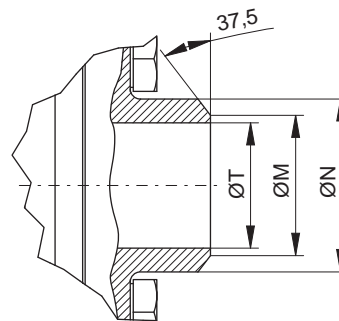

DN	Rp	L ⁽¹⁾	L ⁽²⁾	L ⁽³⁾	L ⁽⁴⁾	M	A	W	ØD	F	ØS	R	ØT	ØM	ØN
	["]	[mm]	[mm]	[mm]	[mm]	[mm]	[mm]	[mm]	[mm]	[mm]	[mm]	[mm]	[mm]	[mm]	[mm]
65*	2½	300	300	294	265	92,5	119	400	62	31,6	73,7	23	65	70	77
80	3	305	305	317	290	100	137	500	76	33,0	89,6	23	80	85	91
100	4	368,5	368,5	369	345	110	157	650	96	37,0	115	29	100	105	115

(1) : gilt für Kugelhahn PN16 / for ball valve PN16
 (2) : gilt für Kugelhahn PN40 / for ball valve PN40
 (3) : gilt für Kugelhahn mit Einschweißenden u. Gewindeanschluß /
 for ball valve with socket weld and threaded connection

(4) : gilt für Kugelhahn mit Anschweißenden /
 for ball valve with butt weld connection
 * Flansche PN16 - DN65 werden in 4-Loch-Ausführung geliefert!
 Flanges PN16 - DN65 will be delivered in 4-hole execution!



**Abmessungen DN125 ... DN200 /
Dimension DN125 ... DN200:**

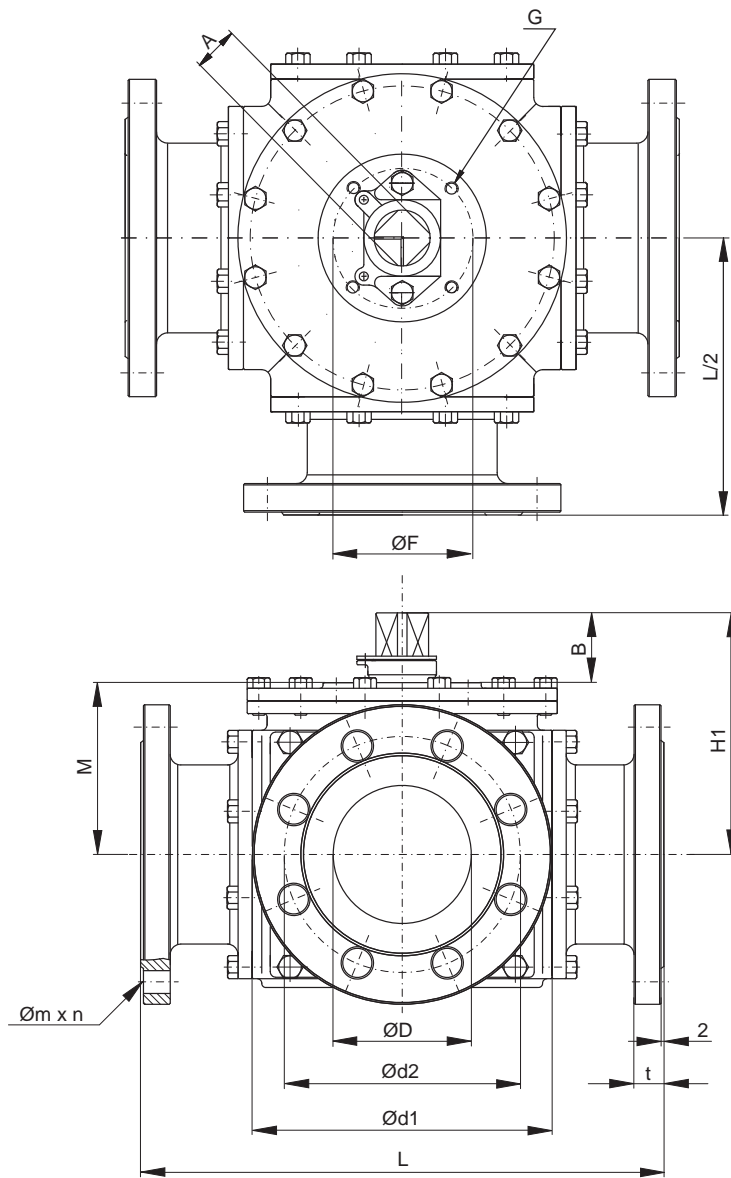

DN	L	H1	H*	M	Ød1	Ød2	n x Øm	B	t	A	G	ØF
	[mm]	[mm]	[mm]	[mm]	[mm]	[mm]	[mm]	[mm]	[mm]	[mm]		[mm]
125	418	198	255	140,5	250	210	8 18	58	22	28	M12	125
150	427	222	298	159,5	285	240	8 22	62	24	36	M12	125
200	532	263	339	201	340	295	12 22	61	24	36	M12	125



*: Höhe mit Handhebel / height with lever

Gewichte[kg] / weight[kg] :

Anschlussart		DN [mm]	15	20	25	32	40	50	65	80	100	125	150	200
		Rp ["]	½	¾	1	1¼	1½	2	2½	3	4	-	-	-
Flanschanschluss	Kugel mit L-Bohrung		4,36	5,62	7,20	10,54	14,52	23,52	28,10	36,58	60,30	90,5	136	234
	Kugel mit T-Bohrung		4,34	5,60	7,14	10,42	14,42	23,40	27,84	35,22	58,90	88	132	224
Gewindeanschluss	Kugel mit L-Bohrung		2,02	2,62	3,71	5,47	8,44	15,36	20,66	27,34	49,74			
	Kugel mit T-Bohrung		2,00	2,62	3,62	5,40	8,27	15,20	20,40	25,98	48,34			
Anschweissenden	Kugel mit L-Bohrung		2,12	2,82	4,01	5,87	9,24	15,56	21,16	27,84	50,54			
	Kugel mit T-Bohrung		2,10	2,82	3,92	5,80	9,07	16,40	20,90	26,48	49,14			



**Kv-wert [m³/h] /
Kv-value [m³/h]:**

Größe / Size DN		L-Bohrung / L-configuration 	T-Bohrung / T-configuration 	T-Bohrung / T-configuration 
15	1/2"	6	6,9	5,2
20	3/4"	6	6,9	5,2
25	1"	9,5	11,2	6,9
32	1 1/4"	9,5	11,2	6,9
40	1 1/2"	25,8	29,2	18,9
50	2"	40,4	46,4	35,3
65	2 1/2"	60,2	72,2	46,4
80	3"	114,4	135,9	83,4
100	4"	139,3	161,7	104,9
125		216,7	236,5	185,8
150		348,3	379,3	309,6
200		1.193	1.432	860,0

